

# KEITH

WALKING FLOOR India

www.keithwalkingfloor.in

# RUNNING FLOOR II<sup>®</sup> DX-i

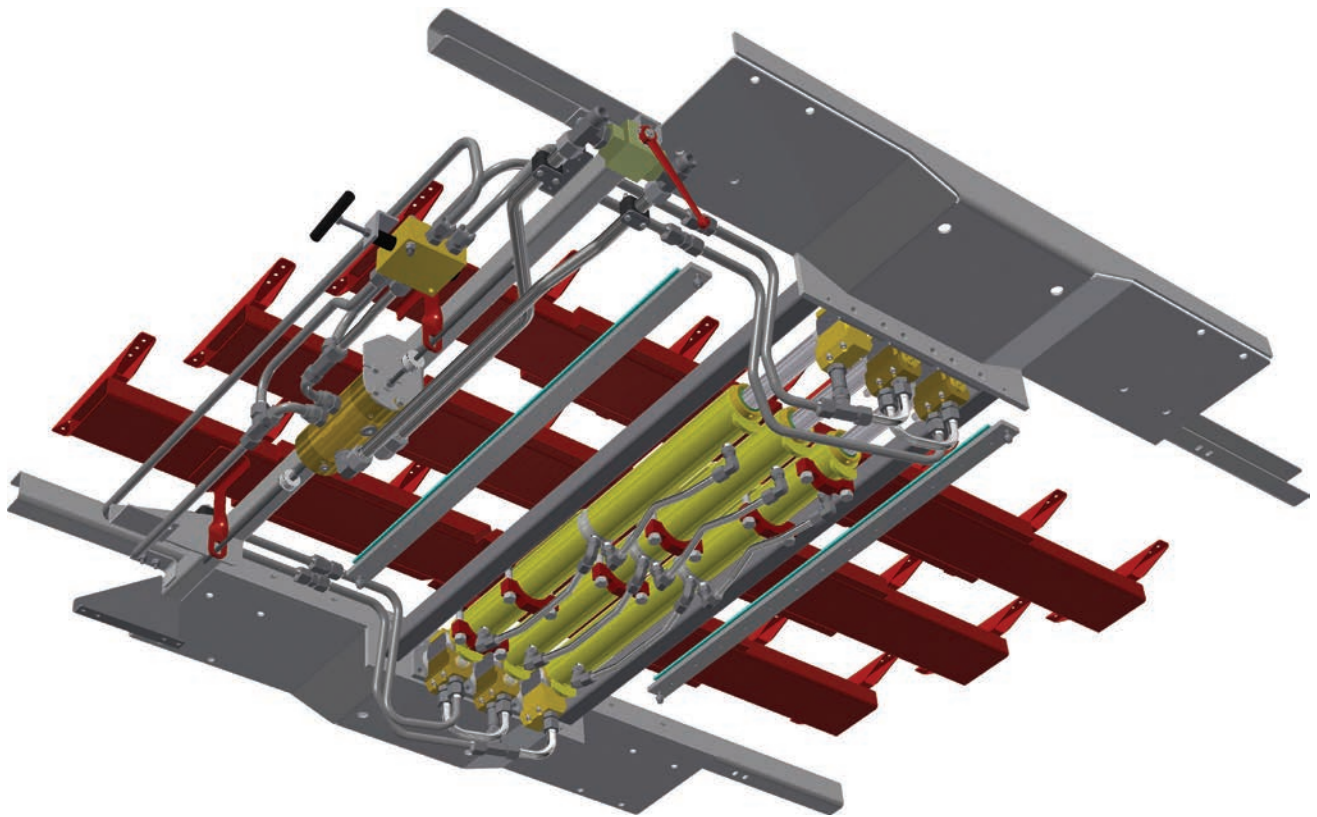

9907201



## OWNER / OPERATOR MANUAL

Original Instructions

©2023 KEITH Manufacturing Co. All Rights Reserved. KEITH, KEITH logo and WALKING FLOOR are registered trademarks of KEITH Manufacturing Co. Equipment manufactured by KEITH Manufacturing Co. is protected by numerous patents both domestic and foreign.

Released: 2023-03-27

DOC06340 Rev. J

## Table of Contents

Introduction	iii
KEITH® RUNNING FLOOR® DX-i Unloading System Limited Warranty	iv
Warranty Registration Card	vi
1.0 Safety	1
1.1 General Safety	1
1.1.1 Intended Function and Expected Use	1
1.1.2 Improper Use	1
1.1.3 Training	1
1.1.4 Personal Protective Equipment	2
1.1.5 Airborne Noise Emission	2
1.1.6 Temperature	2
1.1.7 Lighting	2
1.1.8 Movement Around the System	2
1.1.9 Hydraulic Oil Safety	2
1.2 Design / Installation Safety	3
1.2.1 Kit Components	3
1.2.2 Installation	3
1.2.3 Danger Zones	3
1.2.4 Hydraulics	3
1.2.5 Controls	3
1.3 Marking of Machinery	4
1.3.1 Safety Decals	4
1.3.2 Serial Plate	6
2.0 Specifications	7
2.1 Hydraulic Drive Unit	7
2.2 General Wet Kit Specifications	8
2.3 Floor to Wet Kit Diagram	9
3.0 Operation	10
3.1 How It Works	10
3.2 Oil Flow Diagram	11
3.3 Component Location Guides	13
3.4 Component Descriptions	15
3.5 Component Identification	16
3.6 Start Up	17
3.6.1 Before Initial Start-Up	17
3.6.2 After initial 6 working hours (first week of operation)	17
3.7 Pre-Trip Checklist	17
3.8 Standard Operating Procedure (Manual Controls)	18

**Operating  
Instructions**

4.0	Maintenance	19
4.1	Life Extending Practices	19
4.2	Preventative Maintenance	19
4.2.1	Monthly Service (25 operating hours)	19
4.2.2	6-Month Service (150 operating hours)	19
4.3	Bolt Torque Requirements	20
4.4	Cross-Drive Wear Component Diagram	21
4.5	Flooring Wear Component Diagrams	22
5.0	Troubleshooting	23
5.1	Check List	23
5.2	Problem / Solution - Troubleshooting	23
5.3	Adjustments & Repairs	23
5.4	Technical Support	23
6.0	Contact Information	24

## Introduction

We at KEITH *WALKING FLOOR* India are very happy you have decided to equip your trailer with the KEITH® *WALKING FLOOR*® system. We take great pride in manufacturing the simplest, lowest maintenance self-unloading system available. Installing the KEITH® *WALKING FLOOR*® system in your trailer provides you with the versatility to load or unload virtually any type of material.

The following pages contain information on the operation of your KEITH® *WALKING FLOOR*® system. Further support and safety documents (manuals, brochures, and product specs) can be viewed or downloaded from our website at [www.KeithWalkingFloor.in](http://www.KeithWalkingFloor.in).

In addition, we have provided general information on the type of hydraulic wet kit that will be needed to operate your system. Please contact a KEITH sales representative or visit our website for more specific recommendations regarding pumps, filters, pressure relief valves and approved equivalent equipment. It is critical to adhere to the outlined hydraulic wet kit specifications. Failure to follow the guidelines concerning required operation pressures can lead to system failure due to excessive heat buildup.

If you have any questions, please contact KEITH *WALKING FLOOR* India by calling +91-44-48526805 or emailing [Solutions@KeithWalkingFloor.in](mailto:Solutions@KeithWalkingFloor.in) where our support team will happily assist you.

Thank you again for putting your trust in our company!

Sincerely,



R. Mark Foster  
President

## KEITH® RUNNING FLOOR® DX-i Unloading System Limited Warranty

### 1 Year Limited Warranty & 2 Year Limited Hydraulic Warranty

**KEITH WALKING FLOOR India** hereby warrants, to the first owner of a new **KEITH® Unloading system** from the factory or selling distributor, that the product shall be free from defects in material and workmanship for a period of **one year** after delivery or sale to the first registered owner. The **hydraulic drive system** has a **two year** limited warranty on all hydraulic parts and components. This warranty does not cover normal wear and tear and maintenance. A warranty card must be filled out and returned to **KEITH WALKING FLOOR India** to activate this warranty.

**Unloading system must only be used as recommended by KEITH WALKING FLOOR India** for normal use and service. This means the loading and/or unloading of uniformly distributed, non-corrosive material, properly restrained and secured, on properly maintained public roads, with gross vehicle weights not in excess of factory rated capacity. For stationary installations, normal use and service means the conveying of uniformly distributed, noncorrosive materials, with weights not in excess of factory rated capacity. The system must be installed according to **KEITH WALKING FLOOR India** installation instructions. Preventative maintenance must be performed at regular intervals as specified in **KEITH Manufacturing Co.** manuals. **See below for circumstances that void the KEITH limited warranty.**

**Sole and Exclusive Remedy:** If the product covered hereby fails to conform to the above stated warranty, **KEITH WALKING FLOOR India's** sole liability under this warranty and the owner's sole and exclusive remedy is limited to repair or replacement of the defective part(s) at a facility authorized by **KEITH WALKING FLOOR India**.

**THE WARRANTY SET FORTH ABOVE IS EXPRESSLY MADE IN LIEU OF ANY OTHER WARRANTIES, EXPRESS, IMPLIED, OR STATUTORY. KEITH WALKING FLOOR INDIA MAKES NO WARRANTIES OF FITNESS FOR A PARTICULAR PURPOSE OR WARRANTIES OF MERCHANTABILITY. FURTHER, KEITH WALKING FLOOR INDIA WILL NOT BE LIABLE FOR INCIDENTAL OR CONSEQUENTIAL DAMAGES SUCH AS, BUT NOT LIMITED TO, THE LOSS OF USE OF THE PRODUCT, DAMAGE TO THE PRODUCT, ATTORNEY'S FEES AND THE LIABILITY IN RESPECT TO ANY OTHER REASON.**

**TORT DISCLAIMER: KEITH WALKING FLOOR INDIA EXCLUDES ANY LIABILITY IN TORT WITH RESPECT TO THEIR PRODUCTS, INCLUDING ANY LIABILITY BASED ON STRICT LIABILITY IN TORT AND NEGLIGENCE.**

**If This Warranty Violates Law:** To the extent any provision of this warranty, contravenes the law of any jurisdiction, that provision shall be inapplicable in such jurisdiction and the remainder of the warranty shall not be affected thereby.

#### Warranty Return Policy

Any defective part(s) must be shipped freight prepaid to the **KEITH WALKING FLOOR India** facility. Before returning any item for repair or replacement, contact **KEITH WALKING FLOOR India** at +91-44-48526805 or Solutions@KeithWalkingFloor.in for a "Returned Goods Authorization" (RGA) number. Make sure the RGA number is on the outside of the shipping container and all paperwork is included.

#### The following information is needed:

- |                 |                              |
|-----------------|------------------------------|
| a. Company name | e. Part number               |
| b. Contact name | f. Quantity                  |
| c. Address      | g. Reason for return         |
| d. Phone number | h. Customer's account number |

**The following circumstances void the KEITH Limited Warranty:**

- Unloading system is not installed properly.
- Wet kit is not as recommended by KEITH or using an end dump or dump truck wet kit.
- Malfunction or problems caused by equipment which was not supplied by KEITH.
- Malfunction caused by improper repair work or repair work which is carried out by third parties.
- Malfunction caused using contaminated oil or oil of the wrong type.
- Malfunction caused by excessive heat over 140 °F [60 °C] due to a bad hydraulic pump on the truck or hydraulic wet kit or improper operation of the unloading system, for example, not fully opening and closing the ball valve.
- Defects in electrical components caused by incorrect connection and/or incorrect voltage levels.
- Preventative maintenance is not performed at regular intervals as specified in KEITH manuals.
- Malfunction caused by corrosive materials.
- Malfunction caused by overloading or improper use as stated in KEITH manuals.

**Examples of wear items which are not covered by KEITH Limited Warranty:**

- Floor seals
- Floor bearings
- Floor slats
- End plugs in slats
- Filter elements and components

## Warranty Registration Card

Note: To validate the warranty, the registration information must be filled out completely and returned to KEITH WALKING FLOOR India within ten (10) days of purchase and/or installation.

Please fill out the Warranty Registration form on our website at [www.KeithWalkingFloor.in](http://www.KeithWalkingFloor.in) or fill out the Warranty Registration Card below and mail or email it to:

KEITH WALKING FLOOR India Private Limited  
 B Wing, Level 7, The Capital  
 Bandra Kurla Complex  
 Mumbai, Maharashtra 400051 India  
 Tel: +91-44-48526805  
 Email: Solutions@KeithWalkingFloor.in

-----

This warranty registration card must be completed and on file at KEITH WALKING FLOOR India in order for the warranty period to begin on the purchase date. If no purchase date is registered, the beginning of the warranty will automatically revert to the manufacture date.

Name / Company Name: \_\_\_\_\_

Address: \_\_\_\_\_

City, State: \_\_\_\_\_ Postal Code: \_\_\_\_\_

Country: \_\_\_\_\_

Tel: \_\_\_\_\_

E-Mail: \_\_\_\_\_

### SYSTEM DATA:

Date of Purchase: \_\_\_\_\_

Model / Serial Number: \_\_\_\_\_

Purchased From: \_\_\_\_\_

Type of Material Loaded/Unloaded: \_\_\_\_\_

I have fully read the KEITH WALKING FLOOR India warranty information and fully understand and agree to the terms of the warranty.

Name: \_\_\_\_\_ Date: \_\_\_\_\_ Signature: \_\_\_\_\_

## 1.0 Safety

### 1.1 General Safety

#### 1.1.1 Intended Function and Expected Use

1.1.1.1. The KEITH® *WALKING FLOOR*® system is a reciprocating slat conveyor primarily intended to load, hold, or unload bulk materials. It can also handle unit loads such as pallets by using special handling techniques and possibly additional safety controls. The system is supplied as a kit primarily intended for installation into mobile trailers or truck bodies. The floor is often loaded through an open trailer top or through the rear doors. The floor typically discharges material out the rear door. It is hydraulically actuated, powered by a pump mounted either to a PTO or an electric motor. The basic system is controlled by mechanically-actuated valves, but has the option for electrically-actuated valves. The system is compatible with options and accessories to improve performance. For example, it can be electrically controlled by hardwired switches or a wireless remote. A CleanSweep® device can improve clean out. Floor slat styles are selected based on the materials to be conveyed. The standard system handles a wide array of materials in a non-hazardous, non-explosive environment. Special modifications may be required for special environments like food-grade applications or explosive conditions.

#### 1.1.2 Improper Use

- 1.1.2.1. This equipment has been manufactured utilizing state-of-the-art technology in accordance with acknowledged safety regulations. Nevertheless, dangerous situations could arise from improper use, which could endanger life and limbs of personnel and cause severe damage to the equipment and other assets. This equipment may only be used for its intended purpose. It may only be operated in impeccable technical condition and in accordance with the proper use and this user manual. Problems, which could affect safety, must be resolved immediately. The manufacturer is not liable for any damage caused by improper use or arbitrary modifications. The installation, commissioning, operation, and maintenance instructions must be followed as outlined in this manual.
- 1.1.2.2. Personnel must not enter the danger zone(s) when the system is enabled. Specifically, nobody should be inside, under, or behind the trailer in the unloading zone during operation. Additionally, no one should be in a full or filling trailer. Lock-out and tag-out procedures must be followed before accessing the drive area.
- 1.1.2.3. The maximum load capacity must not be exceeded. (See 2.0 Specifications section)
- 1.1.2.4. The hydraulic power source must not exceed the pressure and flow ratings. Install a relief valve to ensure the maximum pressure is not exceeded.
- 1.1.2.5. Control circuitry must not be altered or bypassed.
- 1.1.2.6. Safeguards must not be altered or bypassed.
- 1.1.2.7. The floor structure must not be altered.
- 1.1.2.8. The floor should not be used to handle any material other than specified.
- 1.1.2.9. The user and system designer must understand the characteristics and safe handling requirements of the material that is being conveyed.
- 1.1.2.10. Bulk materials are by nature unstable and flowable. Avoid burial by avoiding contact with the material.

#### 1.1.3 Training

- 1.1.3.1. Operators must read and understand this manual before operating or maintaining the machine. Only qualified, trained personnel may execute commissioning, operation, and maintenance of the system.

### 1.1.4 Personal Protective Equipment

1.1.4.1. Always wear protective equipment appropriate for risks associated with each phase of the system's life, including transportation, installation, assembly, operation, inspection, maintenance, and dismantling, disabling, and scrapping. As a minimum, this includes the following personal protective equipment:

- Safety glasses
- Protective/traction shoes
- Gloves
- Welding/grinding protection
- Helmets
- Thermal protection such as coats
- Hearing Protection

### 1.1.5 Airborne Noise Emission

1.1.5.1. There is not a defined workstation; sound pressure levels emitted by the *WALKING FLOOR*® modules were measured at a height of 1.6 meters from the floor surface and a distance of 1 meter from the surface of the *WALKING FLOOR*® system at the drive area.

- The A-weighted emission sound pressure level = 74.8 dB
- The peak C-weighted instantaneous emission sound pressure level = below 130 dB [63 Pa]

1.1.5.2. Slower floor speeds result in less noise.

### 1.1.6 Temperature

1.1.6.1. Operation of the system generates heat in the hydraulic oil. Hot oil can damage the internal seals, resulting in a failure to operate.

1.1.6.2. Overheated oil can degrade rapidly. Hot oil and the resulting hot surfaces can cause burns. Do not allow the oil temperature to exceed [60 °C] 140 °F.

1.1.6.3. KEITH recommends some or all of the following temperature control measures depending on the circumstances. High duty cycle systems and hot environments will require more control measures.

- Maintain adequate oil level in the reservoir.
- Install a thermometer or sensor to monitor oil temperature.
- Install a cooler.
- Set a sensor to automatically shut down the system if oil temperature exceeds [60 °C] 140 °F.

### 1.1.7 Lighting

1.1.7.1. Do not use or service the system in an environment of insufficient light.

### 1.1.8 Movement Around the System

1.1.8.1. Hydraulic oil can be slippery. Clean up oil spills immediately.

### 1.1.9 Hydraulic Oil Safety

1.1.9.1. See the Material Safety Data Sheet (MSDS) for the oil used in your system for further information about hydraulic oil safety.

1.1.9.2. In an accident involving high pressure equipment, hydraulic oil may be injected under the skin. Such an accident may result in a small, sometimes bloodless, puncture wound. However, due to the system's driving force, material injected into a fingertip can be deposited into the palm of the hand. Within 24 hours, there is usually a great deal of swelling, discoloration, and intense throbbing pain. Immediate treatment at a surgical emergency center is recommended.

1.1.9.3. Do not use high pressure systems in the vicinity of flames, sparks, and hot surfaces. Use only in well ventilated areas.

1.1.9.4. Use only designated appropriate fill and drain ports for the oil.

## 1.2 Design / Installation Safety

### 1.2.1 Kit Components

- 1.2.1.1. The kit consists of a drive unit, flooring, and miscellaneous boxed parts. These modules are intended to be anchored in a shipping frame or stacked flat and braced with dunnage for shipping and storage.

### 1.2.2 Installation

- 1.2.2.1. Use designated lifting points if provided on drive or shipping frame.
- 1.2.2.2. Only use equipment with appropriate capacity ratings to lift and handle components.
- 1.2.2.3. Use appropriate lifting procedures when handling loose or boxed components.
- 1.2.2.4. The floor must be installed far enough away from other equipment or fixtures to prevent the moving parts of the floor module from creating a crush or pinch hazard.

### 1.2.3 Danger Zones

- 1.2.3.1. The reciprocating action of the floor creates pinch and shear points by nature. Specifically, drive area cylinder, cross-drive, and slats approaching each other, frame components, or walls. These and any other relevant exposed areas must be guarded.
- 1.2.3.2. The floor must be incorporated into surroundings such that movement of the material on the floor does not create crushing, burial, drawing in, or entrapment hazards. The system must be designed to limit access to the material flow path.

### 1.2.4 Hydraulics

- 1.2.4.1. Hydraulic piping and components must be constructed of materials that are rated for system pressures, and must be installed with best industry practices. Follow all pipe, tubing, fitting, and hose manufacturer installation and routing guidelines.
- 1.2.4.2. Hydraulic piping should be supported and isolated from vibration. Contact KEITH for recommendations on installation.
- 1.2.4.3. Place protective shrouds around the hydraulic tubing in any areas that may have operators or people frequently nearby.

### 1.2.5 Controls

- 1.2.5.1. The control devices must be located such that they are easily accessible for all sizes and capacities of people, and allows the operator to move freely (whenever applicable).
- 1.2.5.2. Control devices must be located outside of danger zones, such that any exposed persons in danger zones are visible from the control station.
- 1.2.5.3. An acceptable means must be provided to monitor the status and movement of the load.
- 1.2.5.4. The floor can generate enormous horizontal force which can destroy improperly designed surroundings. The floor module must not be allowed to compact material against an end wall or door, or end walls and doors must be designed to absorb these forces.
- 1.2.5.5. Do not allow the floor to move material toward the front of the trailer when material is contacting the front wall. KEITH recommends installing limit switches to prevent this. In the absence of a sensor switch, the operator must be keenly aware of the load position, and the control system must require the operator to hold the run signal in the on position to continue running, such that releasing the run signal causes the floor to stop (momentary signal).
- 1.2.5.6. Material compacted against closed doors can force the doors open dangerously fast when the door latch is released. The impact can cause serious injury or death. Do not allow the floor to run when the doors are closed. Do not open a door when it is possible that material may be compacted against it. KEITH strongly recommends installing a control interlock switch to prevent the floor from running when the door is closed. KEITH also recommends a door latch that can be remotely actuated by someone away from the door area unload zone.















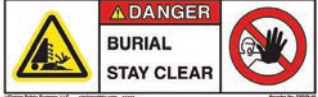



1.3 Marking of Machinery

1.3.1 Safety Decals

Safety Decal Placement Guide: RUNNING FLOOR II® DX/DX-i w/Manual Control Valve (Right Side Controls)



Decal Kit # 84804333

<p><b>Worded</b> (Old - 2019)</p>	<p><b>Wordless</b> (2020 - Future)</p>	<p><b>Description</b></p>
		<p>Pressure can build when material is compacted. Doors can open violently causing serious injury or death. Do not operate floor with doors closed. Stay clear to open doors.</p>
		<p>Pinch point can cut or crush causing serious injury. Stay clear during operation. Lockout/tagout before servicing.</p>
		<p>Burial could cause serious injury or death. Stay clear during operation.</p>
		<p>To avoid injury, you MUST read and understand technical manual before operating or servicing this machine.</p>
		<p>Hydraulic pressure can cause serious injury. Stay clear during operation. Lockout/tagout before servicing.</p>
		<p>Hot surface can cause severe burns. Do not touch. Turn off and lock out main power disconnect and allow to cool before servicing.</p>
		<p>Avoid injury. Do NOT operate with guard removed. Replace guard before operating machine.</p>
		<p>Burial could cause serious injury or death. Do Not Enter when being loaded.</p>
		<p>Pull handle out to turn floor on. Push handle in to turn floor off.</p>
	<p>controls on <u>Right</u> e of Truck/Trailer</p>	<p>Pull handle out to unload. Push handle in to load.</p>

### 1.3.2 Serial Plate

Please fill in the information from the serial plate attached to your drive system (See 3.3 Component Location Diagram). Over time these plates become difficult to read or even locate and this information is crucial in determining the specific replacement parts for your system.

<h1>KEITH</h1> <h2>MANUFACTURING CO</h2> <p>KEITH Manufacturing Co. World Headquarters 401 NW Adler St. Madras, OR 97741 USA</p>	
<b>RUNNING FLOOR II®</b>	
MODEL:	_____
SERIAL #:	_____
D.O.M.:	_____
LOAD CAPACITY:	_____
MAX PRESSURE:	_____
MAX FLOW:	_____
DRIVE WEIGHT:	_____
<p><a href="http://www.KeithWalkingFloor.com">www.KeithWalkingFloor.com</a> WALKING FLOOR and KEITH are registered trademarks of KEITH Manufacturing Co.</p>	



## 2.0 Specifications

### 2.1 Hydraulic Drive Unit

Drive Style:		KRFII-3	KRFII-3.5
Cylinder Bore Diameter:		76 mm [3.0 in]	89 mm [3.5 in]
Cylinder Stroke Length:		203 mm [8.0 in]	203 mm [8.0 in]
Required Relief Valve Pressure Range:	Min:	195 bar [2,800 PSI]	195 bar [2,800 PSI]
	Max:	210 bar [3,000 PSI]	210 bar [3,000 PSI]
Load Capacity:		31.75 tonnes [35 tons]	45.5 tonnes [50 tons]
Pump Flow Rate:		19 - 227 liters/min [5 - 60 gal/min]	19 - 227 liters/min [5 - 60 gal/min]
Recommended Pump Flow Rate:		151 - 170 liters/min [40 - 45 gal/min]	151 - 170 liters/min [40 - 45 gal/min]
* Floor Speed:		0.3 - 5 meters/min [1 - 16.5 ft/min]	0.3 - 3.5 meters/min [1 - 11.5 ft/min]
Max Temperature:		60 °C [140 °F]	60 °C [140 °F]
** Drive Weight:		454 - 500 kg [1000 - 1100 lbs]	612 - 658 kg [1350 - 1450 lbs]

\* Load/Unload times vary with pump flow rate, length of trailer, material type or other environmental variables.

\*\* Varies by drive configuration and application.

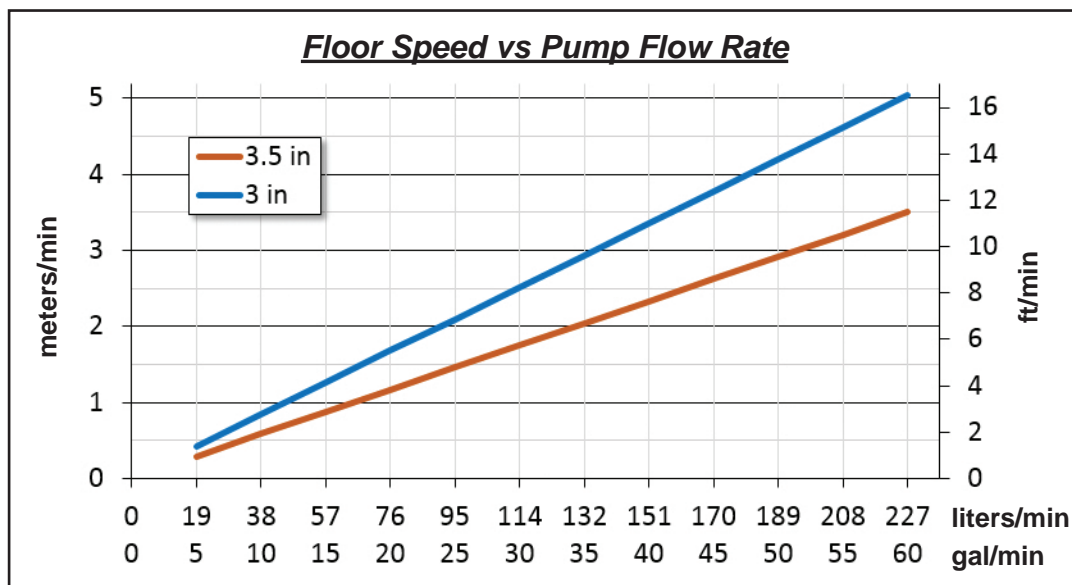

## 2.2 General Wet Kit Specifications

<b>Oil</b>	ISO-L-HM 46 hydraulic oil (As per ISO 11158). If operating the system below 0 °C [32 °F], AW ISO 32 hydraulic oil is recommended.
<b>* PTO &amp; Pump</b>	<p>Hollow axle: B8x 32x 36 DIN 5462 (ISO 14), Mounting Flange: ISO 7653 (80 mm x 80 mm M12 bolt-quantity 4) capable of producing between 151-227 liters/minute at less than 210 bar for optional operation.</p> <p>Spherical head piston pump. Bezares FR110 or MR125, Spline axle: B8x32x36 DIN 5462 (ISO 14) or equivalent, Mounting Flange: ISO 7653 (80 mm x 80 mm, M12 bolt-qty (4)).</p> <p><b>NOTE:</b> Dump wet kit systems will not properly operate the <i>WALKING FLOOR</i>® unloader.</p> <p><b>NOTE:</b> Pumps with built-in pressure relief valves are NOT recommended.</p> <p>Do not exceed the maximum pressure.</p>
<b>Filter</b>	<p>Filter should be 10 micron (or equivalent), on the return line. (The filter element should be changed after the initial 6 hours of operation, then every 6 months thereafter. This may vary with the operating environment).</p> <p>KEITH recommends, but does not require, installing an inline pressure filter to increase the life of the system.</p>
<b>Hydraulic Reservoir</b>	Sized to desired flow rate. Should hold approximately 1 liter [1 gallon] of oil for every liter per minute [gallon per minute] you plan to pump, i.e. 151 liters/min [40 gal/min] = 151 liter [40 gallon] reservoir. Minimum size 151 liters [40 gallons]
<b>Suction Line</b>	Unless tank is mounted above the pump, the suction line from the tank to the pump should be no more than 1.5 m [5 ft] in length with a minimum inside diameter of 51 mm [2 inch] [-32]. Must use <b>suction</b> hose <i>ONLY</i> !
<b>Pressure Line</b>	Hose from wet kit to trailer should be rated at 3000 PSI minimum with a minimum inside diameter of 25 mm [1 inch] [-16]. EN 856 4SP-06
<b>Return Line</b>	Hose from trailer to wet kit filter should be rated at 3000 PSI minimum with a minimum inside diameter of 25 mm [1 inch] [-16]. EN 856 4SP-06
<b>* Pressure Relief Valve</b>	High quality valve, capable of relieving maximum pump flow rate at 210 bar [3000 PSI]. Relief valve must be set above cracking pressure ~ 195 bar [2800 PSI] and no higher than full open relief pressure ~ 210 bar [3000 PSI]
<b>Contact KEITH in your region for specific recommendations and advice regarding wet kits.</b>	

\* If the information about your pump and pressure relief valve is not known, have a pressure/flow check done by a professional.

2.3 Floor to Wet Kit Diagram

**IMPORTANT**  
 To ensure proper operation of your KEITH® WALKING FLOOR®, the specifications and following diagram must be followed. Failure to comply with these instructions may void the KEITH® Warranty.

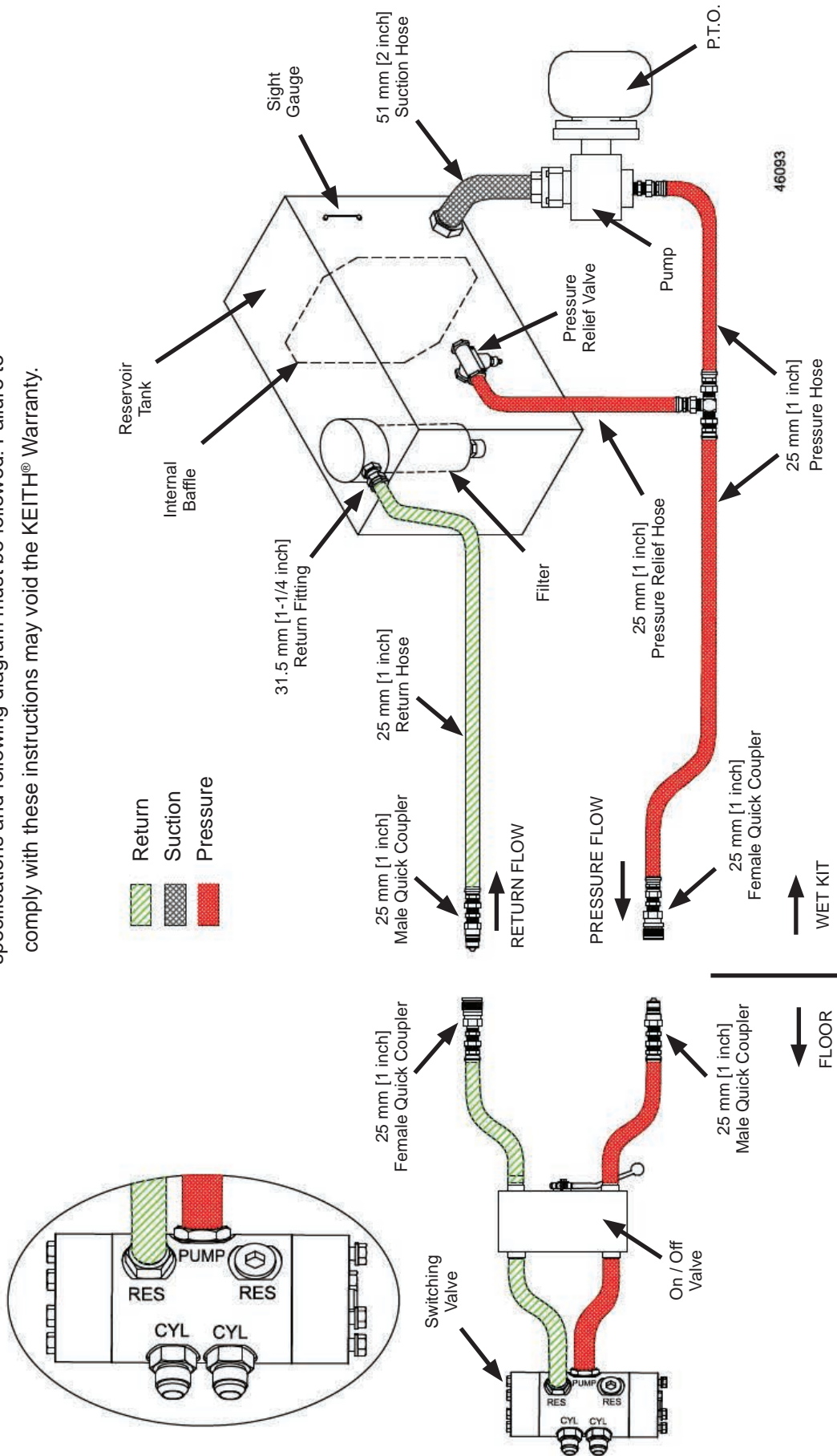

## 3.0 Operation

### 3.1 How It Works

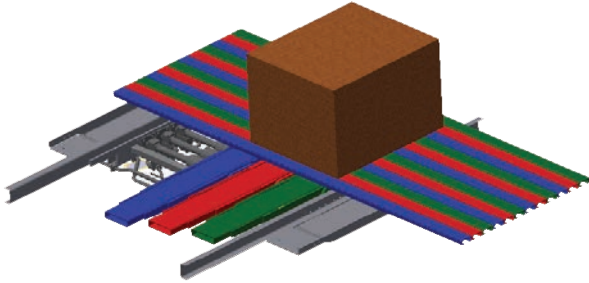

#### Initial Stage

All slats are staged together toward the direction of material travel (discharge end).

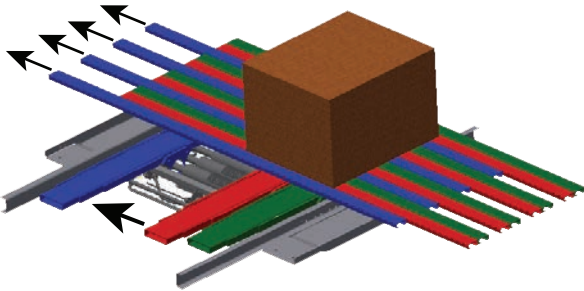

#### Stage 1

The first group of slats (approximately every 3rd slat) moves under the load.

**Load does not move.**

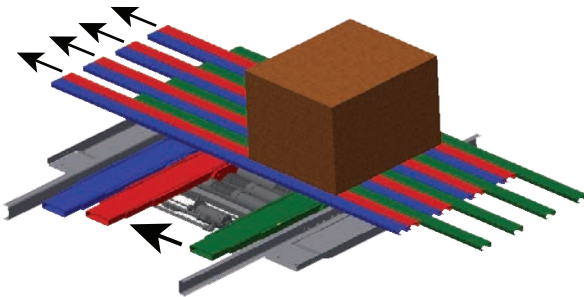

#### Stage 2

The second group of slats moves under the load.

**Load does not move.**

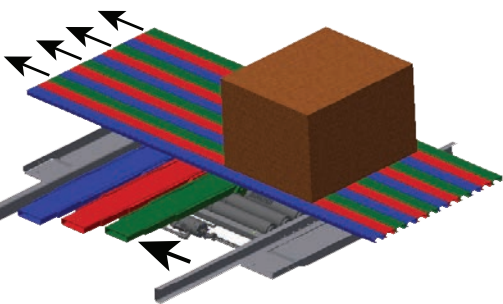

#### Stage 3

The final group of slats moves under the load.

**Load does not move.**

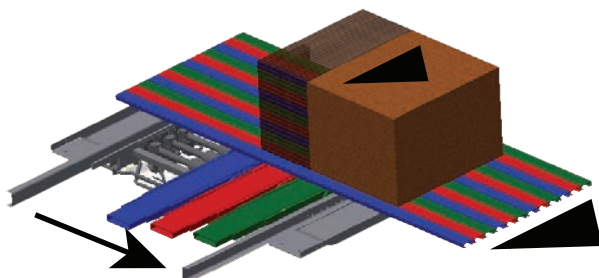

#### Stage 4

All slats move together.

**Load moves with the floor toward the discharge end.**

(Stages 1, 2 & 3 require more pressure than Stage 4.)

8175101

3.2 Oil Flow Diagram

UNLOADING CYCLE

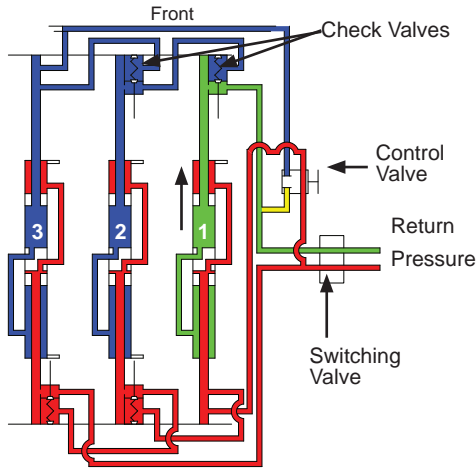

Stage 1

- Pressure in the rear of all cylinders.
- Cylinder #1 is open to return, causing it to move. (Load does not move.)
- Blocked by check valves.

Note: Stage 1 requires more pressure than stage 4.

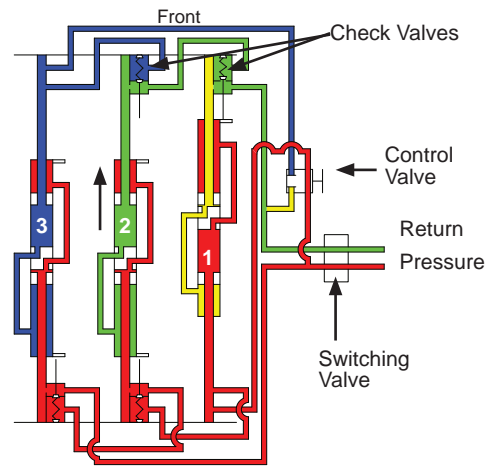

Stage 2

- Pressure still in rear of all cylinders.
- Cylinder #1 completes its full stroke, opening the check valve, allowing the oil in cylinder #2 to escape, causing it to move. (Load does not move.)
- Blocked by check valve.

Note: Stage 2 requires more pressure than stage 1.

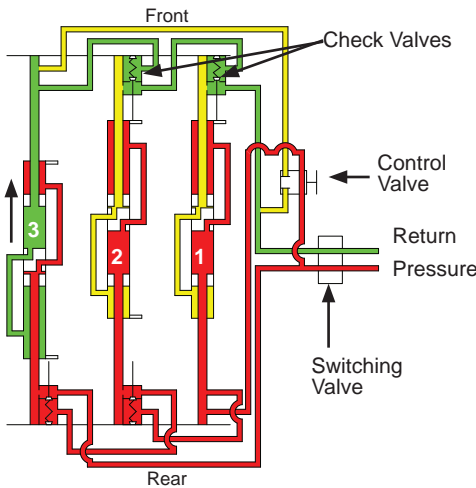

Stage 3

- Pressure still in rear of all cylinders.
- Cylinder #2 completes its full stroke, opening the check valve, allowing the oil in cylinder #3 to escape to return, causing it to move. (Load does not move.)

Note: Stage 3 requires more pressure than stage 2.

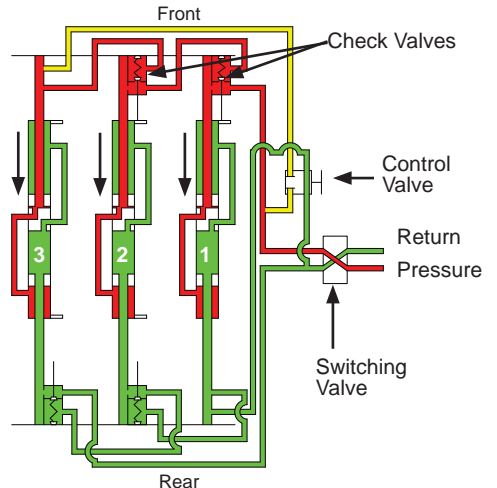

Stage 4

- Cylinder #3 completes its stroke, shifting the switching valve, which reverses pressure and return, transferring the pressure to the front of all cylinders.
- All cylinders are now open to return and move to the rear of the trailer together, moving the load.

As the cylinders complete their stroke, cylinder #1 shifts the switching valve, which reverses pressure and return, transferring the pressure to the rear of all cylinders again and the cycle starts over.

Note: Stage 4 requires less pressure than stages 1, 2, or 3.

## LOADING CYCLE

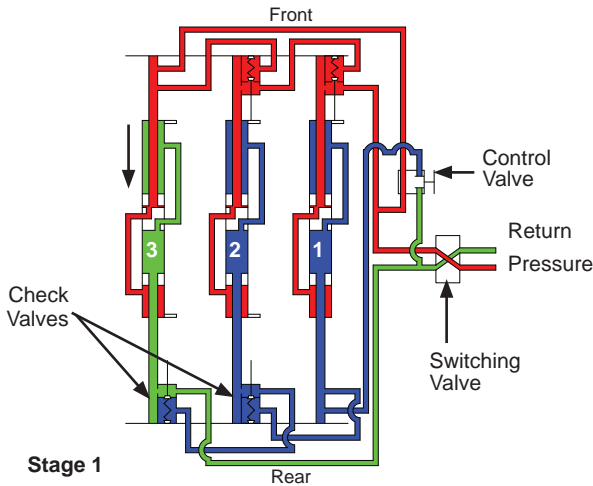

**Stage 1**

- Pressure in the front of all cylinders.
- Cylinder #3 is open to return, causing it to move. (Load does not move.)
- Blocked by check valves.

**Note:** Stage 1 requires more pressure than stage 4.

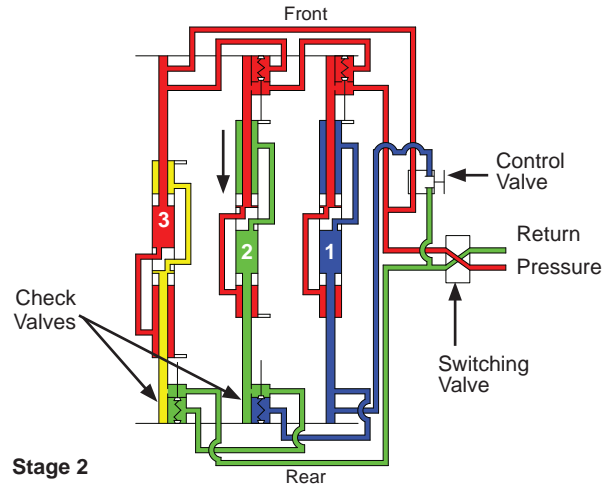

**Stage 2**

- Pressure still in front of all cylinders.
- Cylinder #3 completes its full stroke, opening the check valve, allowing the oil in cylinder #2 to escape, causing it to move. (Load does not move.)
- Blocked by check valve.

**Note:** Stage 2 requires more pressure than stage 1.

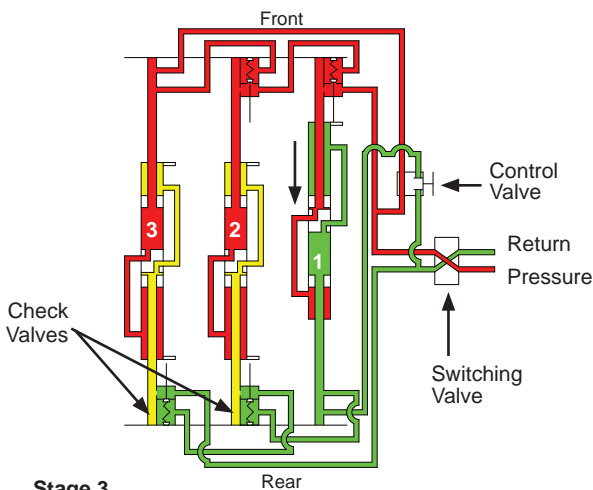

**Stage 3**

- Pressure still in front of all cylinders.
- Cylinder #2 completes its full stroke, opening the check valve, allowing the oil in cylinder #1 to escape to return, causing it to move. (Load does not move.)

**Note:** Stage 3 requires more pressure than stage 2.

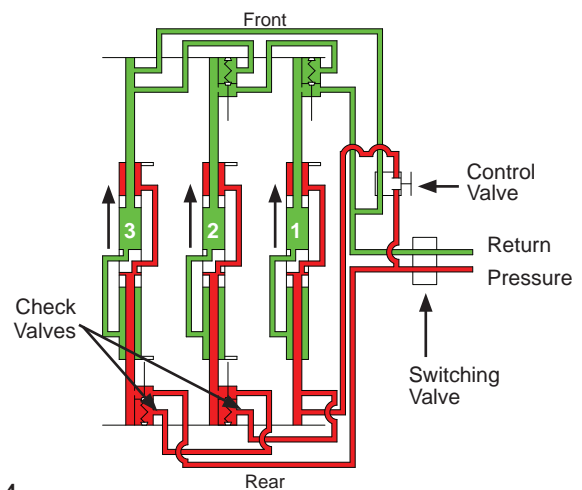

**Stage 4**

- Cylinder #1 completes its stroke, shifting the switching valve, which reverses pressure and return, transferring the pressure to the rear of all cylinders.
- All cylinders are now open to return and move to the front of the trailer together, moving the load.

As the cylinders complete their stroke, cylinder #3 shifts the switching valve, which reverses pressure and return, transferring the pressure to the front of all cylinders again and the cycle starts over.

**Note:** Stage 4 requires less pressure than stages 1, 2, or 3.

3.3 Component Location Guides

# RUNNING FLOOR II® DX-i 3.5”

## Manual Controls (Right Side)

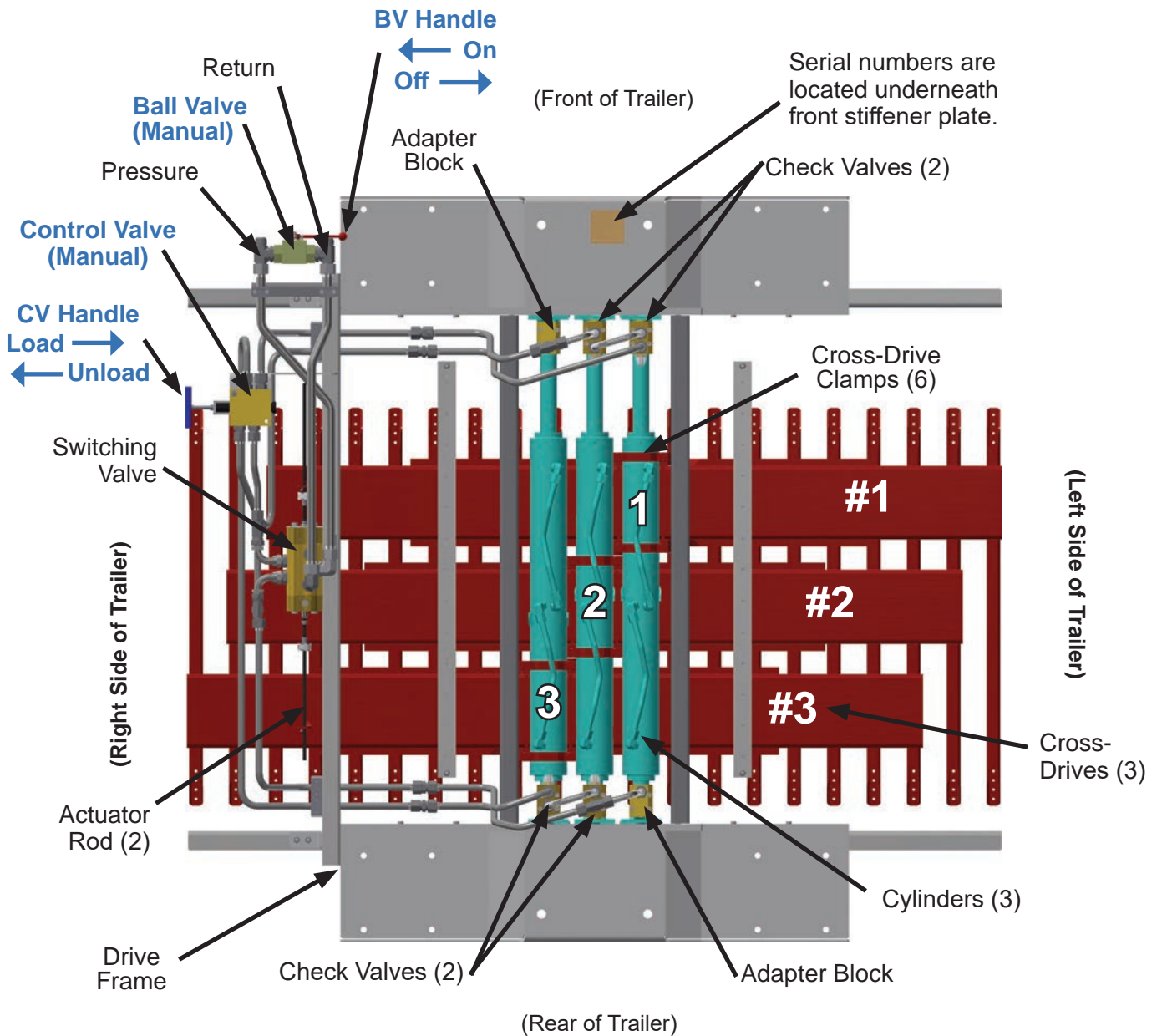

View From Underneath Trailer

10350101

# RUNNING FLOOR II® DX-i 3.0''

## Manual Controls (Right Side)

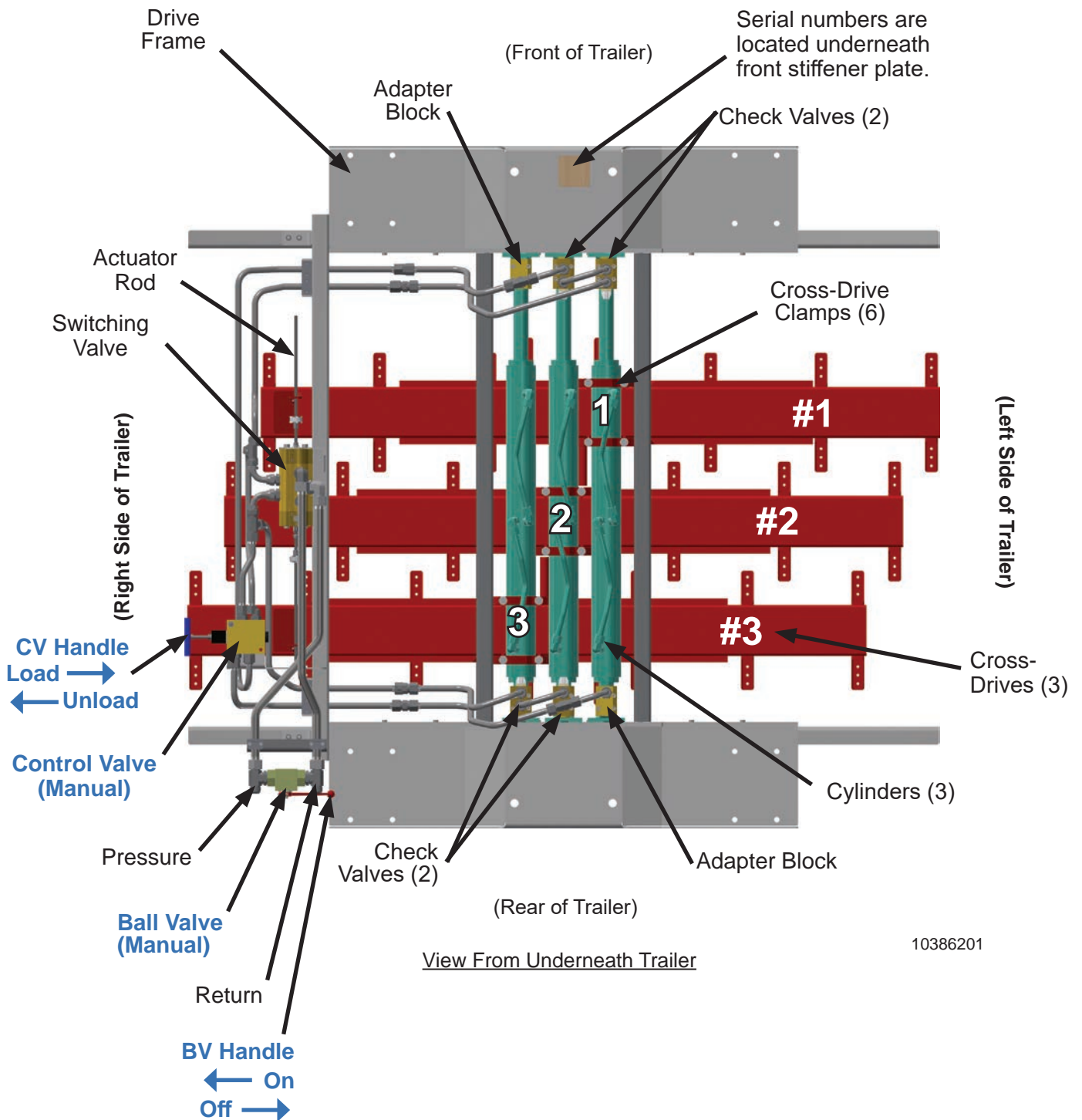

## 3.4 Component Descriptions

<u>Component</u>	<u>Description</u>
<b>Ball Valve (On/Off)</b>	A closed ball valve routes oil to the drive system (floor On). An open ball valve allows free flow of oil back to the tank (floor Off).
<b>Switching Valve</b>	Switches the hydraulic pressure from one end of the cylinders to the opposite end of the cylinders, which causes the cylinders to change from the restaging sequence to moving the material then back again.
<b>Actuator Rod</b>	Threaded rod is used to shift the switching valve for proper operation. <b>Floor will stop if not adjusted properly!</b>
<b>Control Valve (Load/Unload)</b>	Controls which check valves are active, determining the direction of material movement (Load/Unload).
<b>Check Valves</b>	Block oil flow, determining the cylinder restaging sequence.
<b>Cylinders</b>	Move the cross-drives.
<b>Cross-Drive Clamps</b>	Attach each cross-drive to a cylinder.
<b>Cross-Drives</b>	Each cross-drive is connected to one cylinder, allowing each cylinder to move multiple floor slats.
<b>Drive Shoes</b>	Connect the floor slats to the cross-drives and allow multiple floor slats to be attached to each cross-drive.
<b>Cross-Drive Supports</b>	Help maintain the position of the cross-drives over the mainframe rails.
<b>Drive Frame</b>	Provides structural rigidity and a surface to mount the drive to the trailer.

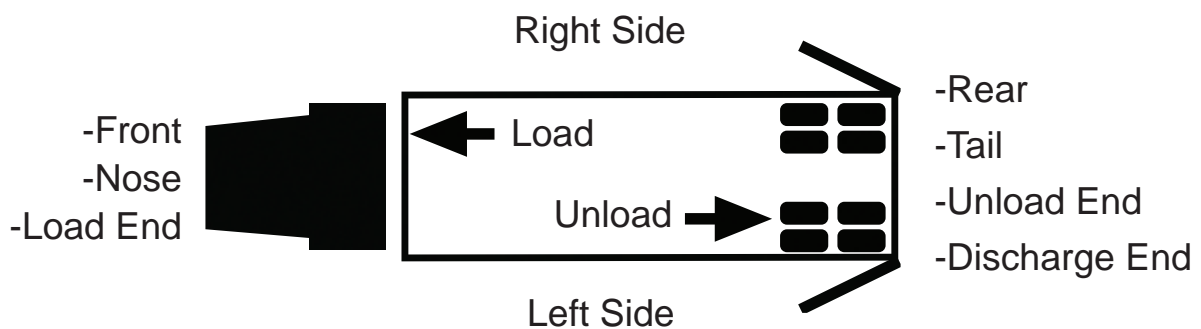

3.5 Component Identification

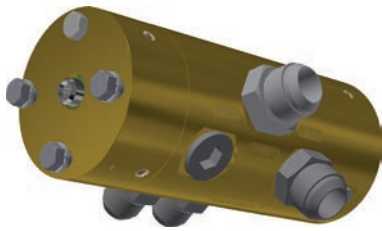

Switching Valve

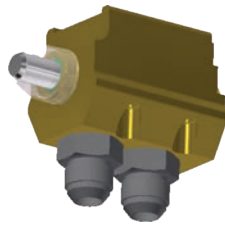

Check Valve



Adapter Block

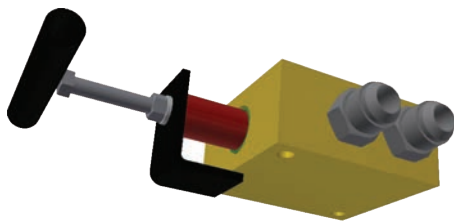

Control Valve



Ball Valve

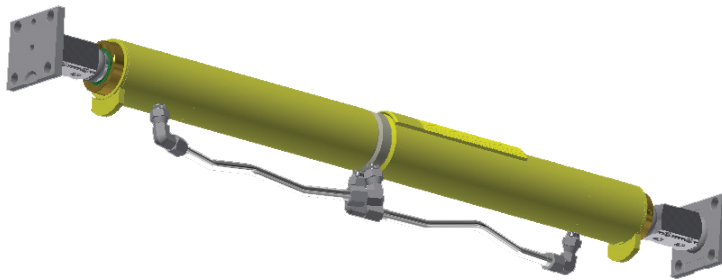

Cylinder

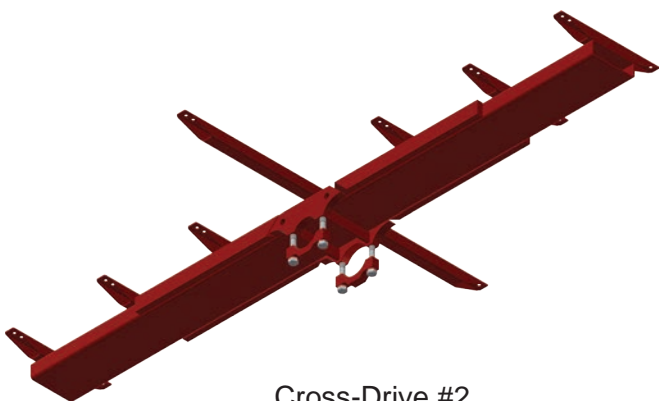

Cross-Drive #2

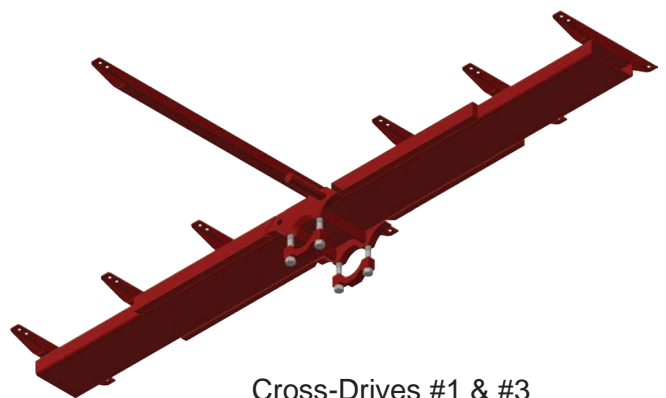

Cross-Drives #1 & #3

(Shape, size and quantity of shoes on cross-drives may vary by configuration.)

### 3.6 Start Up

#### 3.6.1 Before Initial Start-Up

- Read through this manual. If there is any confusion, contact KEITH to resolve any concerns before operating this system (See 6.0 Contact Information section).
- Ensure that the hydraulic reservoir has the recommended amount of oil as well as the correct type of oil (See 2.2 Specifications section or visit our website for additional details).
- Torque cylinder barrel clamp bolts and floor bolts. (See 4.3 Maintenance section for special values and instructions.) Loose cylinder clamp bolts and flooring bolts are the most common cause of severe damage to the drive or flooring.
- Familiarize yourself with 4.2 Preventative Maintenance section of this manual. Following the maintenance schedule will significantly improve the life of the system.

#### 3.6.2 After initial 6 working hours (first week of operation)

- Visually inspect the system for hydraulic leaks. If any leaks are found, retighten fittings.
- Change oil filters. This will ensure that any contamination that was flushed out in the start-up will not prematurely wear out your system.
- Torque cylinder barrel clamp bolts and floor bolts. (See 4.3 Maintenance section for special values and instructions.) Loose cylinder clamp bolts and flooring bolts are the most common cause of severe damage to the drive or flooring. Any bolts that were loose should be checked weekly until found to be tight.

### 3.7 Pre-Trip Checklist

- ✓ Inspect hoses and quick connectors for damage and contamination. Clean all dirt and water from connectors before hooking up (if applicable).
- ✓ Inspect drive unit for leaking fittings or hoses, and visible damage.
- ✓ Open truck or trailer doors and inspect flooring for damage. Inspect flooring at the rear of the truck or trailer for loose or bent slats that may have popped up.
- ✓ Hook up hydraulic connectors (if applicable). Operate the floor and inspect for leaks. Test the On/Off for proper operation. Test the load/unload for proper operation.
- ✓ If problems are found, report them to the maintenance shop as soon as possible.
- ✓ Secure truck or trailer doors and proceed.

As the driver, you will see damage or operational problems before anyone else. Please report issues and concerns as soon as possible.

 **WARNING:** Observations may be made while system is operating for troubleshooting purposes, but NEVER touch any moving part or attempt to make any adjustments to the system with the Power Take Off/Pumping system engaged or the *WALKING FLOOR*® unloader operating.

 **WARNING:** Do not attempt to make adjustments or repairs without consulting with a trained service technician from your company or KEITH (See 5.4 Technical Support section for contact information.)

### 3.8 Standard Operating Procedure (Manual Controls)

**⚠ DANGER:** ALWAYS have doors fully open! NEVER, under any circumstances, engage the *WALKING FLOOR*® unloader with the doors of the truck/trailer closed. Catastrophic failure to the truck/trailer, as well as serious injury or death may occur.

**⚠ DANGER:** Use caution when opening doors. Material can become compacted against doors and they can open violently causing serious injury or death.

**⚠ DANGER:** NEVER allow anyone to stand or move through the area where the load is being discharged or go under truck/trailer body or enter truck/trailer while the system is operating. Burial, loss of limb or life may occur.

**⚠ WARNING:** While unloading, NEVER leave truck and trailer unattended.

1. Set parking brake on the truck/trailer and follow the Pre-Trip Check List.
2. Inspect hydraulic hoses and quick connects for contamination or damage (if applicable), then connect the floor to the truck wet kit.
3. If the load is covered with a tarp, remove and secure the tarp prior to engaging the floor.
4. Manually open truck/trailer rear door(s) fully and secure door(s) with provided chains or loop rings.
5. Place control valve handle (See figure below) in the required position for the desired direction of material movement (Unload/Load).

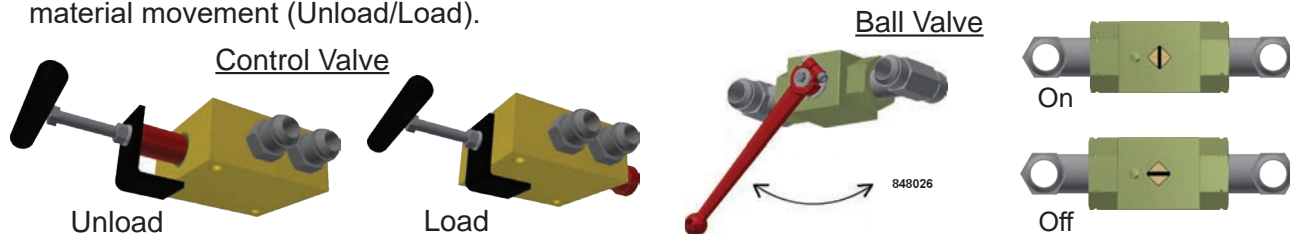

6. Push ball valve handle in (See figure above) to the fully open (OFF) position. The floor will not operate! Ball Valve handle is located between the pressure and return lines. **NOTE:** The ball valve controls On/Off and is used as an emergency stop.
7. Engage PTO (Do NOT increase engine RPM's from idle). This allows hydraulic oil to start flowing through the pump and warming up before engaging the floor (ideally to 80 °F [27 °C]).
8. Fully open hydraulic cover and/or hydraulic rear truck/trailer door(s) (if equipped).
9. Pull out the ball valve handle to the fully closed (ON) position. **The floor will start to operate!**
10. Increase truck engine RPM's to predetermined setting to achieve desired flow rate from the wet kit.
11. When unloading, material will begin to pile up behind the truck/trailer. The load will stop moving when the pile of material gets too high. Reduce engine RPM's and move the truck/trailer forward (load will begin to move again). Repeat until the material is completely unloaded.
12. After loading/unloading is completed, reduce engine RPM's to idle and stop the floor with all slats in the forward position by pushing the ball valve handle in to the fully open position.
13. Fully retract CleanSweep® tarp (if equipped) to the front of the truck/trailer.
14. Close and secure the rear truck/trailer door(s).
15. Disengage PTO.

**EMERGENCY STOP:** In case of emergency the floor can be stopped in one of the following ways:

- Disengage the PTO.
- Push the ball valve fully open.

## 4.0 Maintenance

 **DANGER:** The extreme forces exerted by the floor, when in operation, can result in damage to equipment, as well as cause serious injury or death. Always follow lockout/tagout procedures. Switch off the Power Take Off (PTO) and manually push the ball valve to the fully open position during maintenance and/or service work.

### 4.1 Life Extending Practices

- Follow the Start-Up procedures in this manual.
- Use only clean oil, free from contamination.
- Regularly inspect the system for loose bolts. Loose cylinder clamp bolts and flooring bolts are the most common cause of severe damage to the drive or flooring.
- Be aware of the pressures your system typically runs at (with and without loads). Increased pressure can indicate potential problems.

### 4.2 Preventative Maintenance

#### 4.2.1 Monthly Service (25 operating hours)

- Check the system for hydraulic leaks.
- Check the operating temperature. No single component should be warmer than 60 °C [140 °F] while the system is running.
- Torque cylinder barrel clamp bolts and floor bolts. (See 4.3 Maintenance section for special values and instructions.) Any bolts that were loose should be checked weekly until found to be tight.
- Pressure wash drive unit, sub-deck, and slats (recommended quarterly, minimum twice per year).

#### 4.2.2 6-Month Service (150 operating hours)

- Change the oil filters.
- Cycle the system briefly in both directions and observe to ensure proper operation. Do NOT allow material to compact against the front of the trailer or against the rear doors.
- Inspect cross-drive support bearings, wearpads, tubes and shoes for wear. (See 4.4 Cross-Drive Wear Component Diagram section). Replace as needed.
- Inspect floor bearings and seals for excessive wear (especially above the tires). (See 4.5 Flooring Wear Component Diagrams section) Replace as needed.
- Inspect floor slats for wear. If discharge end of slats are worn down more than 75% of original material thickness rotate all floor slats, end for end, to increase life of the floor. If floor has already been rotated, contact KEITH for replacement slats.

4.3 Bolt Torque Requirements

Description	Size	Quantity	Torque Values
Tube Clamps	M6 CL8.8 HCS 1/4 in GR5 HCS	Varies	Snug
Check Valve & Adapter Block Bolts	M8 CL12.9 SHCS 5/16 in A574 SHCS	4 per valve/block	27 N·m 20 ft-lbs]
Control Valve	M10 CL10.9 HCS 3/8 in GR8 HCS	1	61 N·m [45 ft-lbs]
Switching Valve Bolts	M10 CL10.9 HCS 3/8 in GR8 HCS	3	61 N·m [45 ft-lbs]
Cylinder Rod End Bolts (Requires anti-seize LB8060)	M16 CL10.9 HCS 5/8 in GR8 HCS	8 per cylinder	183 N·m [135 ft-lbs]
Barrel Clamp Bolts	M16 CL10.9 HCS 5/8 in GR8 HCS	4 per cylinder	183 N·m Max ** [135 ft-lbs] Max **
Floor Bolts (Flat Head)	M8 CL10.9 FHCS (90°) 5/16 in GR8 FHCS (82°)	Varies	27 N·m [20 ft-lbs]

\* Bolts installed using thread lock should be checked using a setting that is 7 N·m [5 ft-lbs] less than the above specified value. If the bolt moves then you should remove it, clean it, apply new loctite to the threads and torque it to the full specified value.

\*\* Over tightening the barrel clamp bolts can deform the cylinder barrel shape causing the system to not function properly.

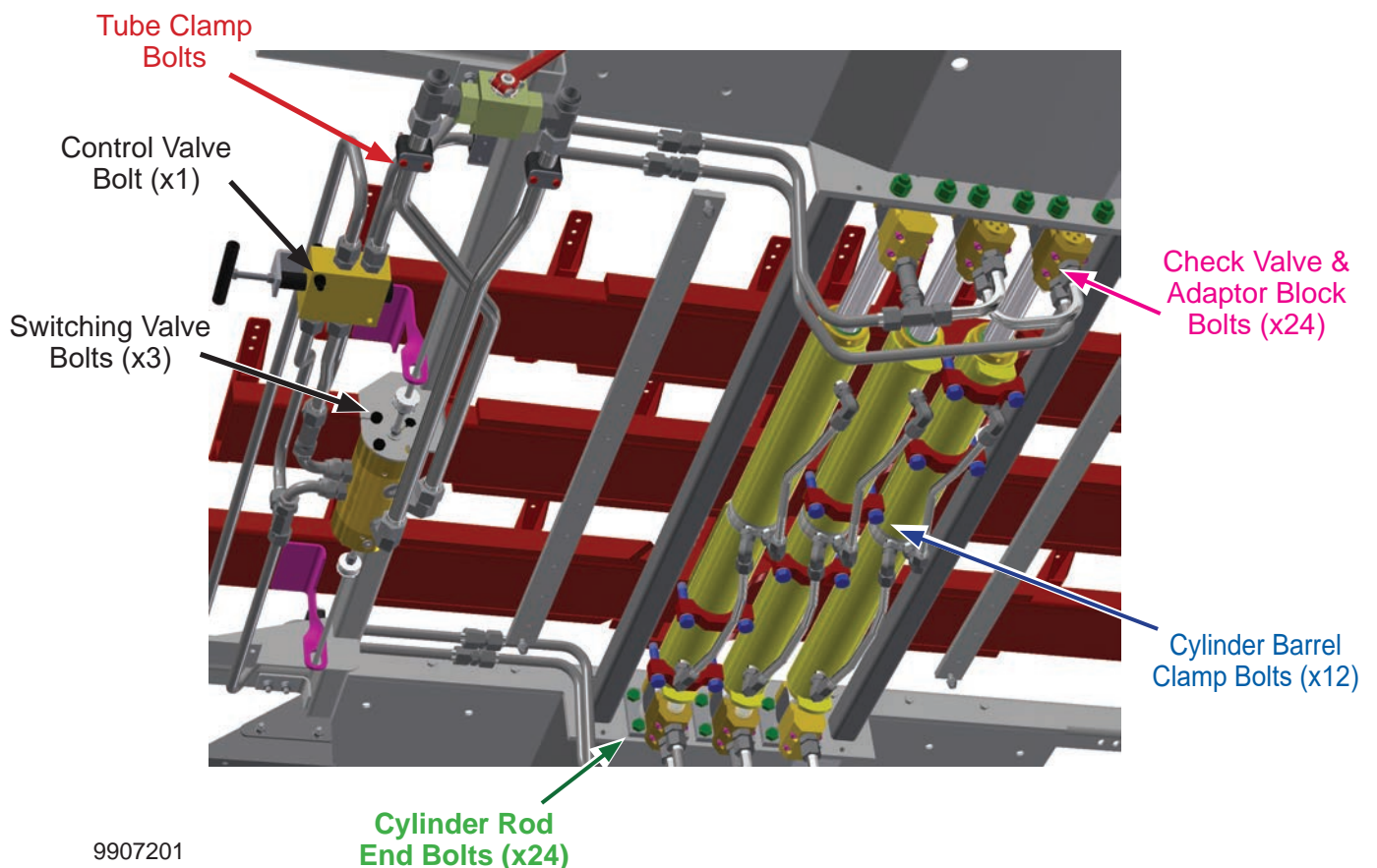

### 4.4 Cross-Drive Wear Component Diagram

Cross-Drive Assembly (shown in red)

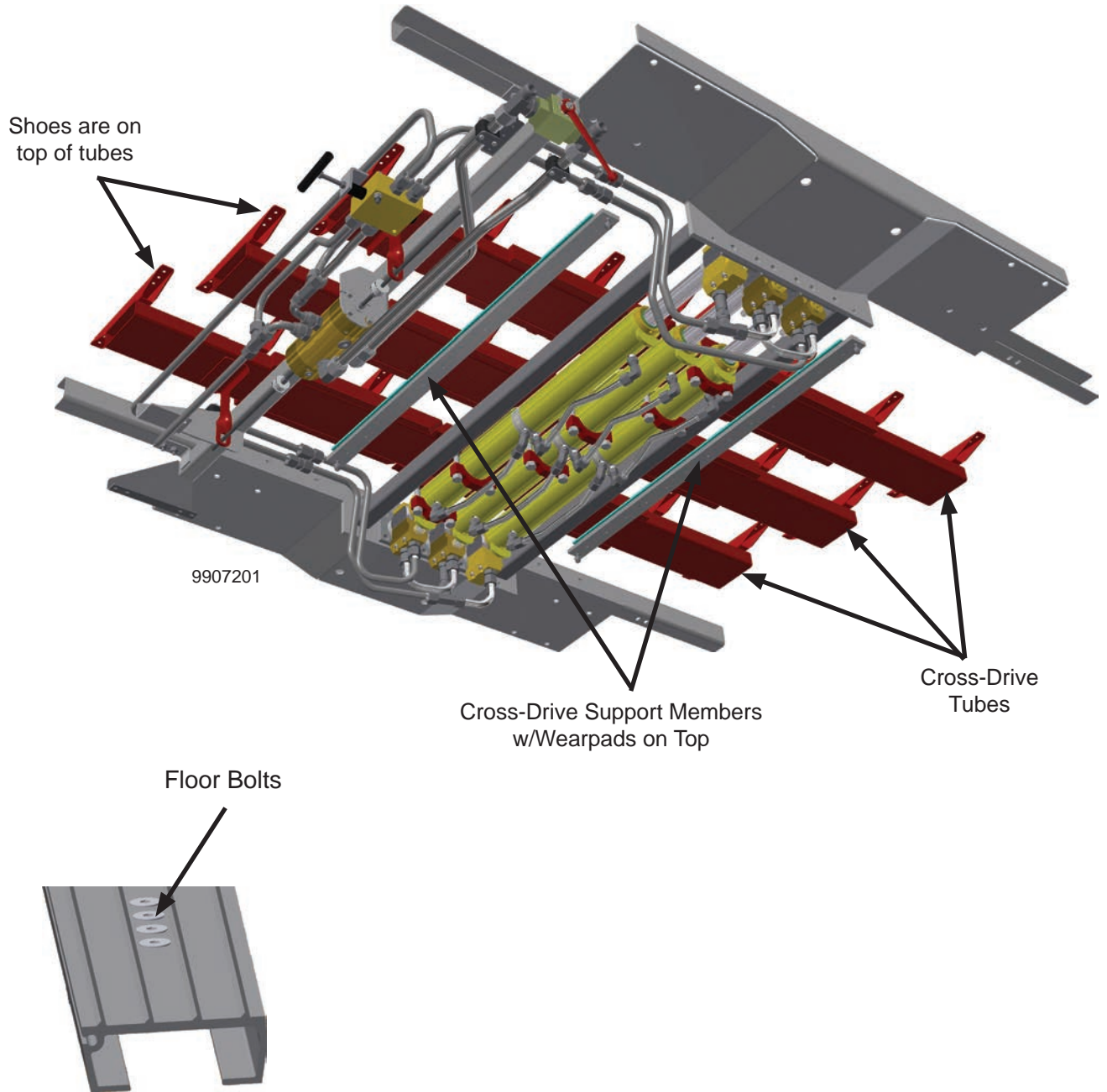

4.5 Flooring Wear Component Diagrams

Floor Wear Bearings & Seals \*

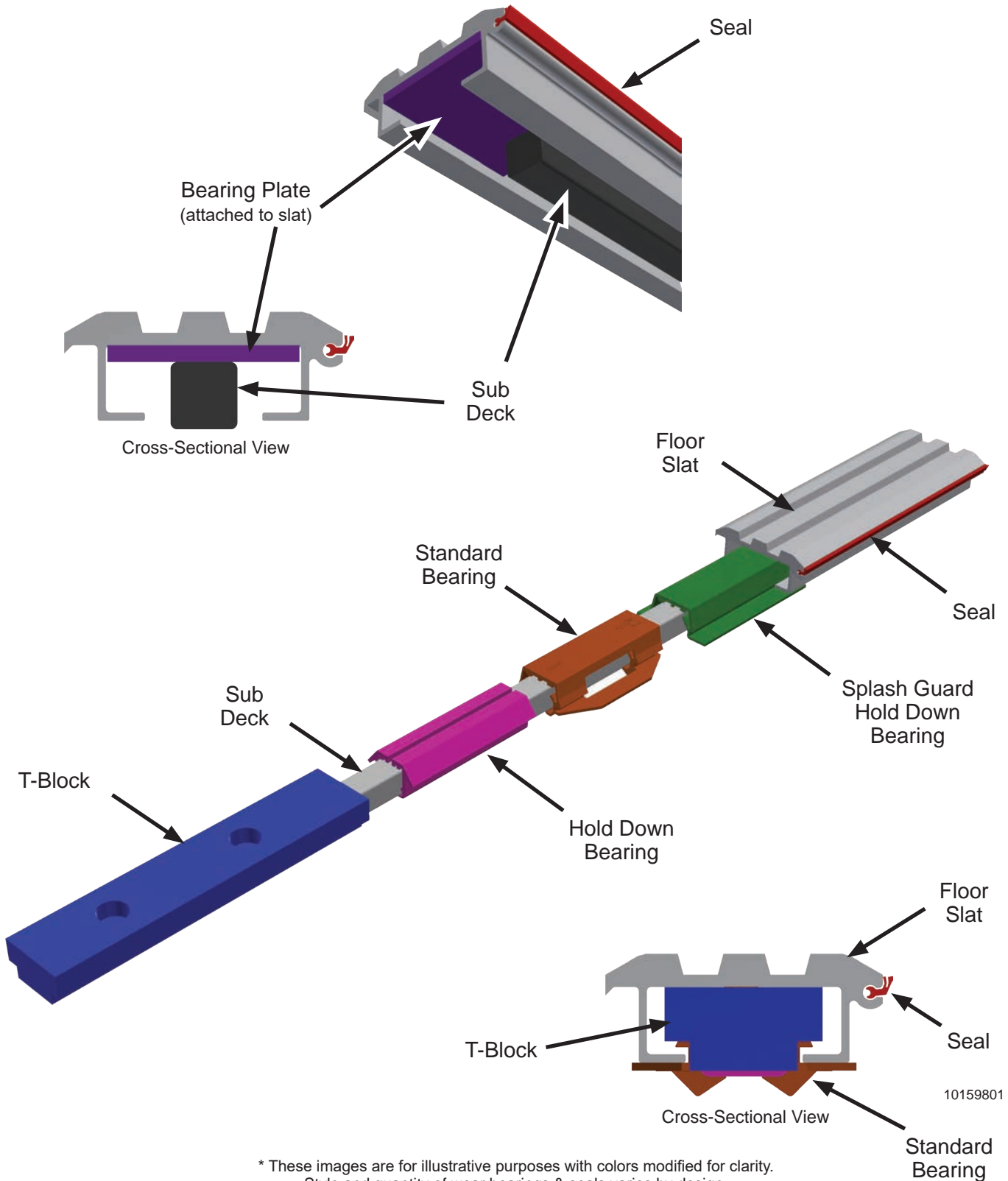

\* These images are for illustrative purposes with colors modified for clarity. Style and quantity of wear bearings & seals varies by design. Wear bearings & seals are non-metallic and run the length of the floor. (They are designed to be replaced to extend the life of the floor.)

10159801

## 5.0 Troubleshooting

### 5.1 Check List

Before contacting KEITH *WALKING FLOOR* India for technical assistance please verify the following:

- ✓ Wet Kit: Does your entire wet kit system meet the requirements in 2.2 Specifications section in this manual? (Additional Wet Kit information is available on our website.)
- ✓ Plumbing: Is your entire system plumbed per the 2.3 Floor to Wet Kit Connection Diagram in Specifications section in this manual?
- ✓ Connections: Inspect the quick connects on the hydraulic lines for damage or contamination. Are the pressure line and return line quick disconnects the correct size and style and are they securely attached between the wet kit and floor and are they connected Pressure to Pressure, Return to Return?
- ✓ Pump: Does it meet minimum requirements in 2.2 Specifications Section?
- ✓ Relief Valve: Is it set per the requirements in 2.2 Specifications Section?
- ✓ Oil: Is the oil reservoir full?
- ✓ Power Take Off: Is the PTO engaged?
- ✓ Ball Valve: Is the ball valve, that engages the drive unit (On/Off), pulled fully closed?
- ✓ Control Valve: Is the control valve fully engaged in the appropriate position (Load/Unload)?

### 5.2 Problem / Solution - Troubleshooting

See information in Troubleshooting section of KEITH website  
<https://www.keithwalkingfloor.com/support/troubleshooting/>

### 5.3 Adjustments & Repairs

See information and videos in Troubleshooting section of KEITH website  
<https://www.keithwalkingfloor.com/support/troubleshooting/>

### 5.4 Technical Support

Please have the following information readily available before contacting KEITH *WALKING FLOOR* India for support:

- Model Number (Located on the Serial Plate of the drive unit) (See 3.3 Component Location Diagram)
- Serial Number (Located on the Serial Plate on the drive unit) (See 3.3 Component Location Diagram)
- Quantity & length of floor slats
- Vehicle make and unit installer

## 6.0 Contact Information

**KEITH WALKING FLOOR India Private Limited**

Paragon 4B - 26

Phoenix Marketcity

LBS Marg, Kurla, Mumbai, Maharashtra 400070

Tel: +91-44-48526805

Email: Solutions@KeithWalkingFloor.in

**KEITH Manufacturing Co.****World Headquarters - USA**

401 NW Adler St.

Madras, OR 97741

Tel: +1-541-475-3802

Email: Sales@KeithWalkingFloor.com